

# てん 点つなぎ ① - 2

ねん がつ 日にち なまえ ( )  
年 月 日 名前 ( )

うえ え おな した うつ  
上の絵と同じように × をつないで下に写しましょう。

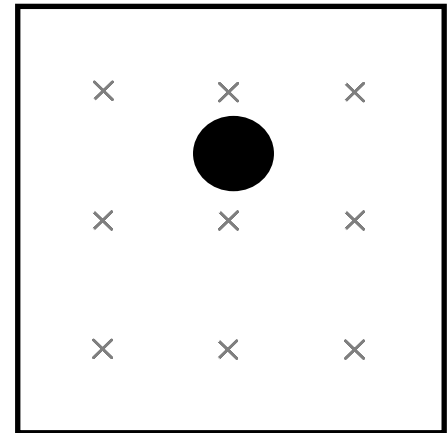

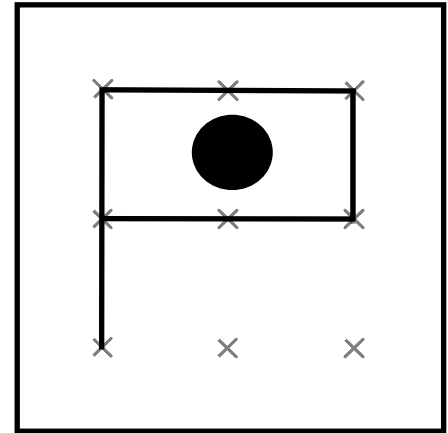
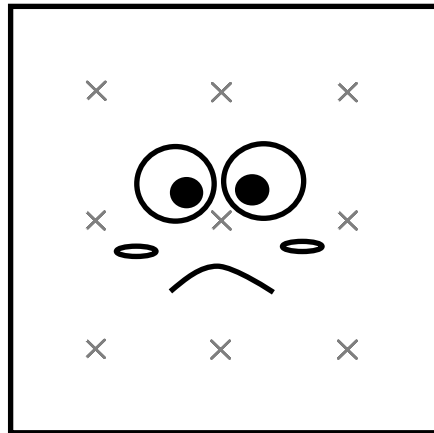
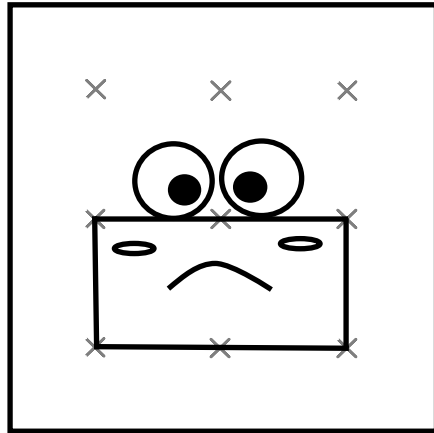
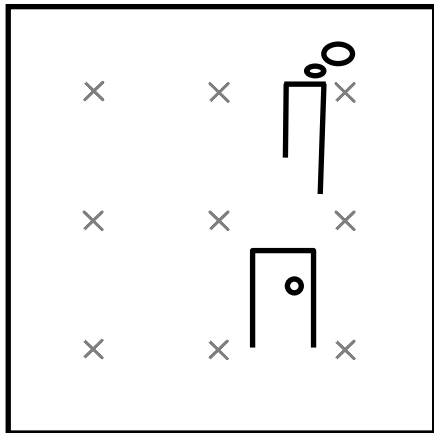
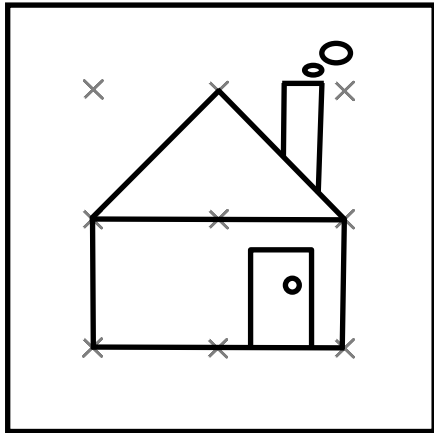
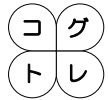

てん  
点つなぎ ① - 3

ねん がつ にち なまえ ( )  
年 月 日 名前

うえ え おな  
上の絵と同じように × をつないで下に写しましょう。  
した うつ

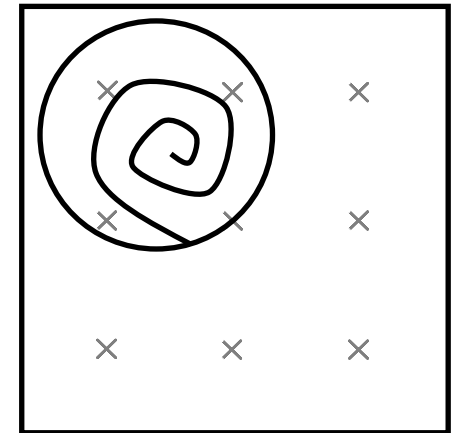
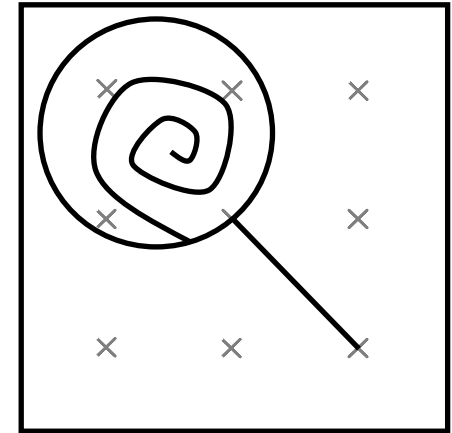
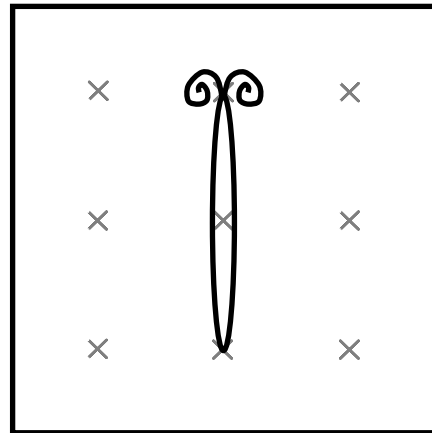
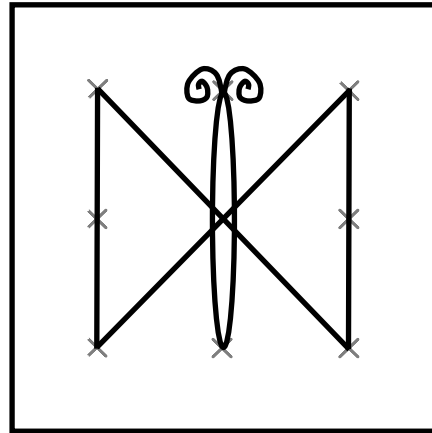
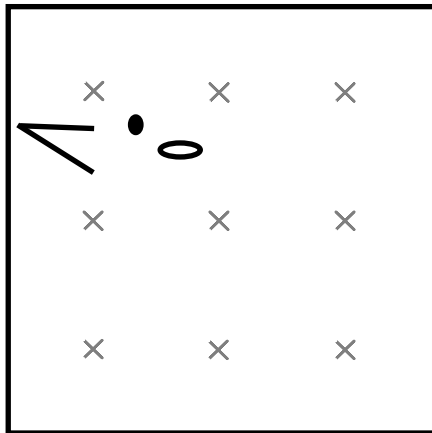
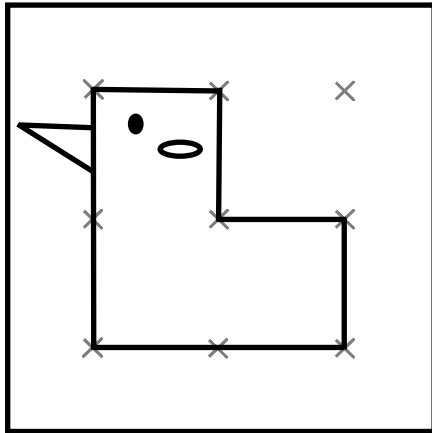

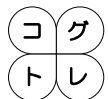

てん  
点つなぎ ① - 4

ねん 年    がつ 月    にち 日    なまえ 名前 (    )

うえ え おな    した うつ  
上の絵と同じように × をつないで下に写しましょう。

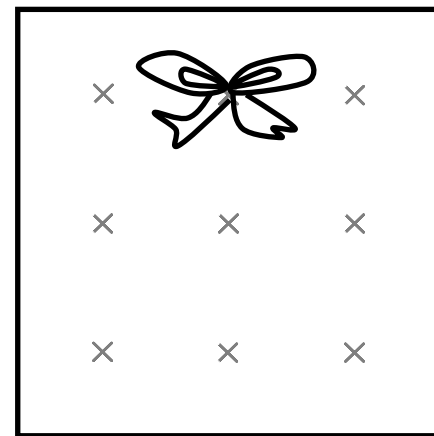
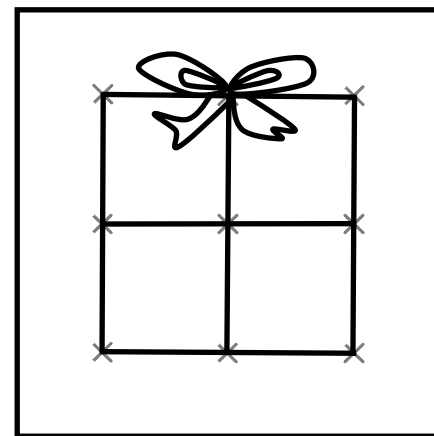
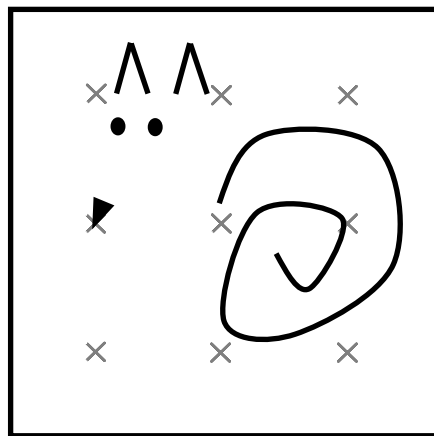
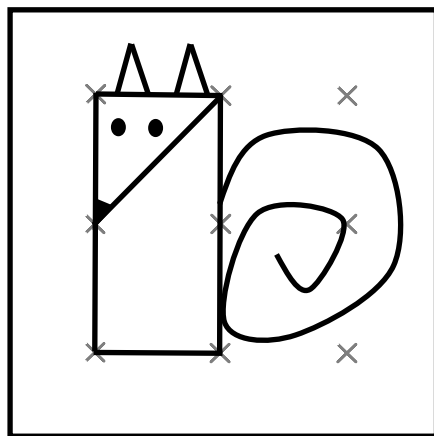
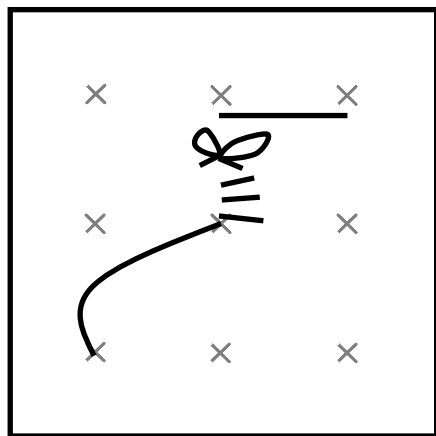
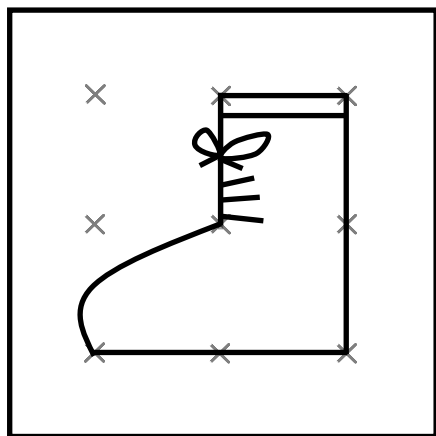

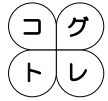

# てん 点つなぎ ① - 5

ねん がつ にち なまえ ( )  
年 月 日 名前

うえ え おな した うつ  
上の絵と同じように × をつないで下に写しましょう。

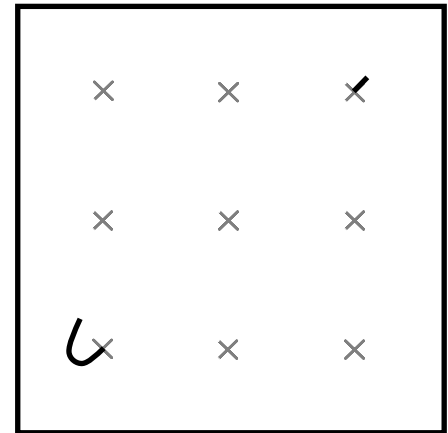
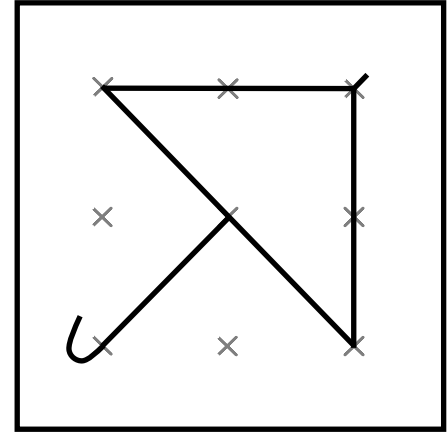
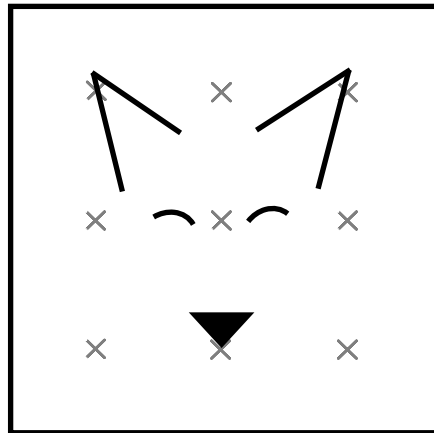
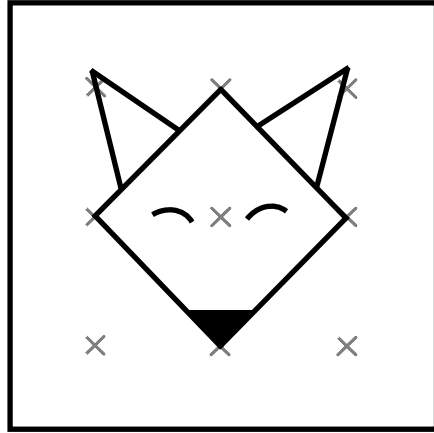
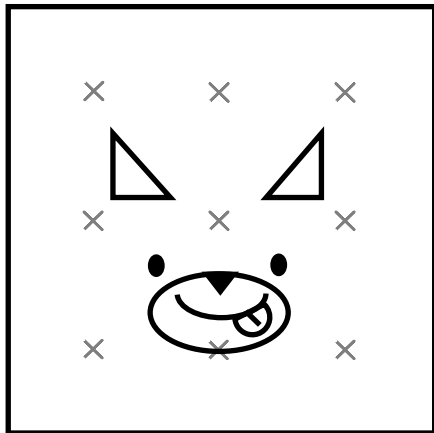
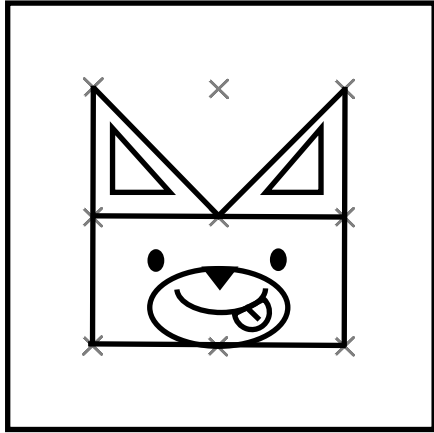

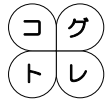

# てん 点つなぎ ① - 6

ねん 年    がつ 月    にち 日    なまえ 名前 (    )

うえ え おな    した うつ  
上の絵と同じように × をつないで下に写しましょう。

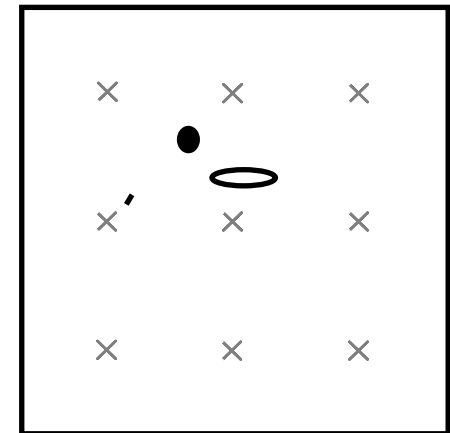
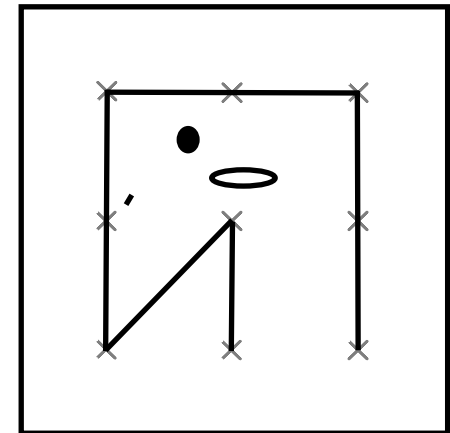
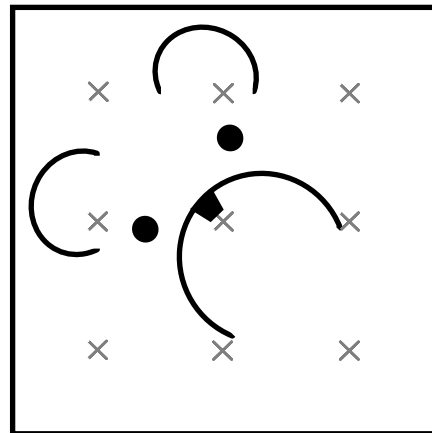
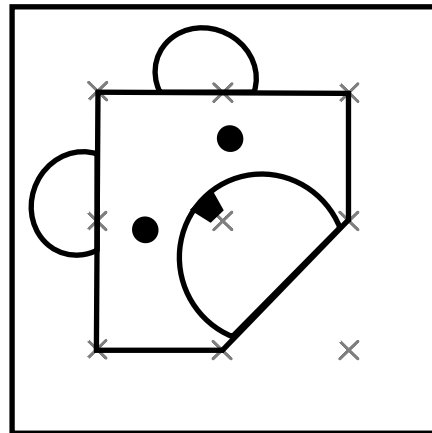
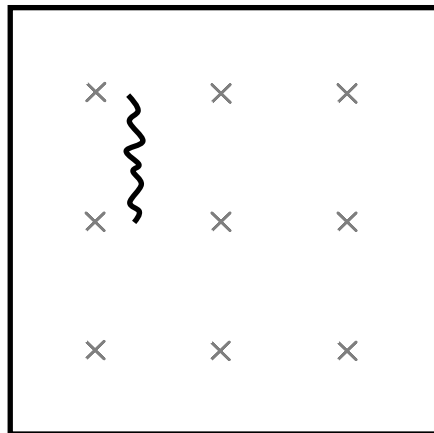
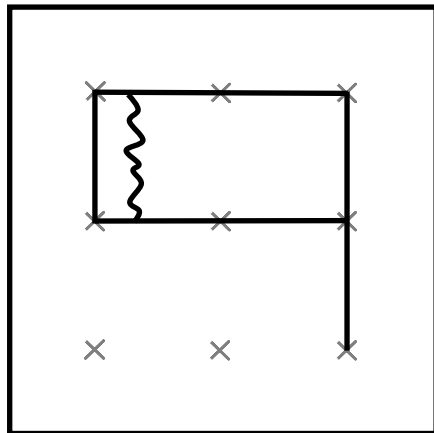

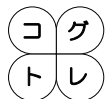

# てん 点つなぎ ① - 7

ねん がつ 日にち なまえ ( )  
年 月 日 名前 ( )

うえ え おな  
上の絵と同じように × をつないで下に写しましょう。  
した うつ  
下 写す

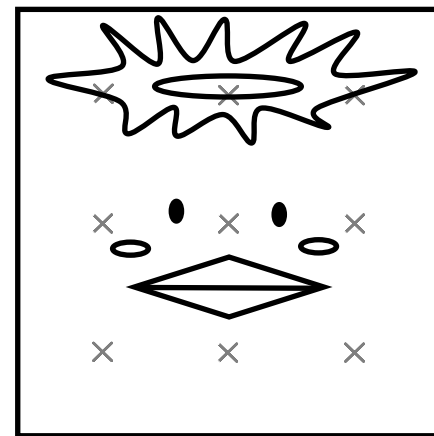
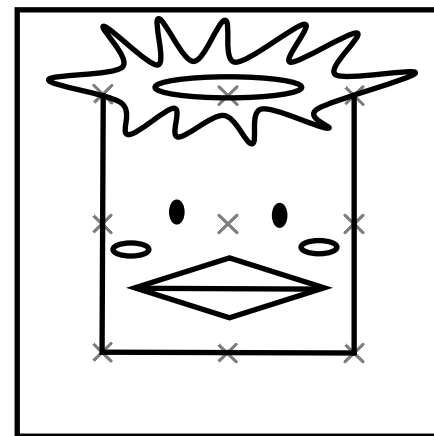
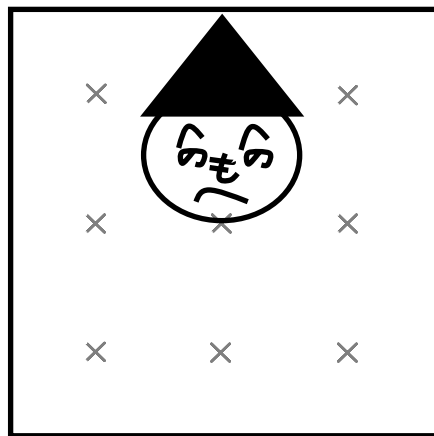
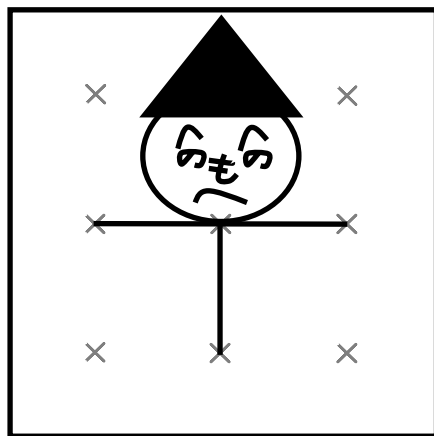
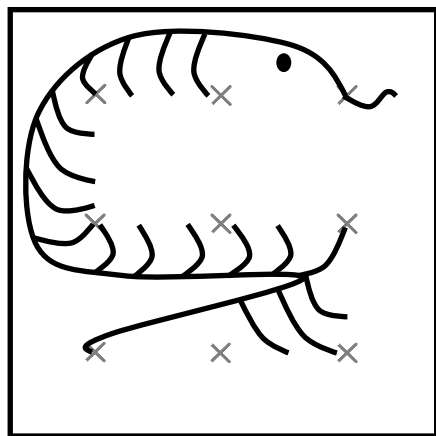
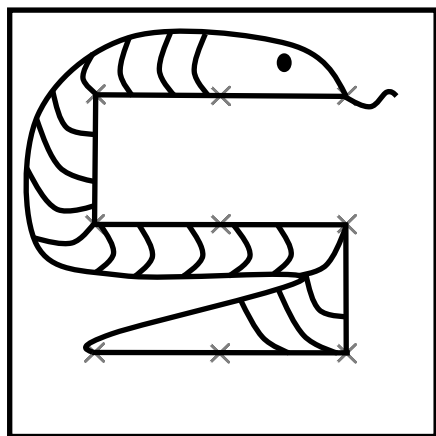

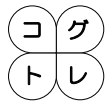

てん  
点つなぎ ① - 8

ねん がつ 日にち なまえ ( )  
年 月 日 名前 ( )

うえ え おな  
上の絵と同じように × をつないで下したにうつ写しましょう。

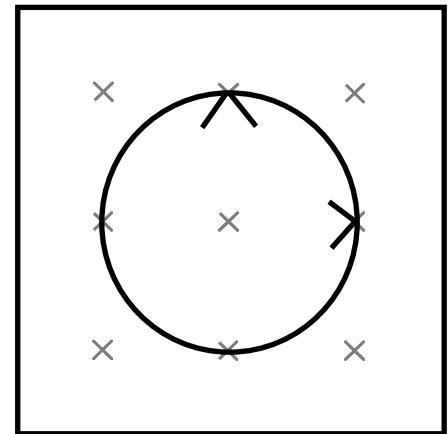
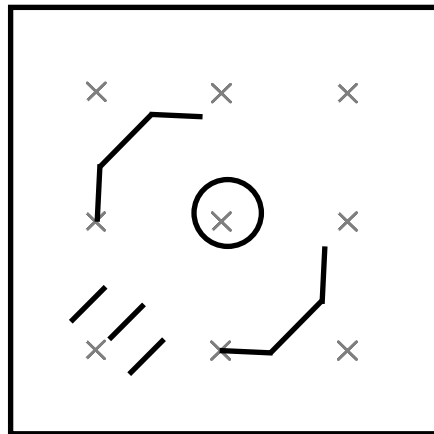
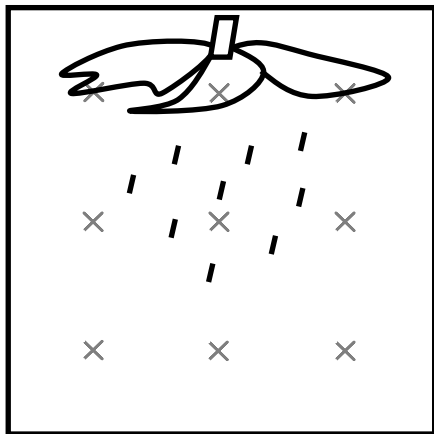
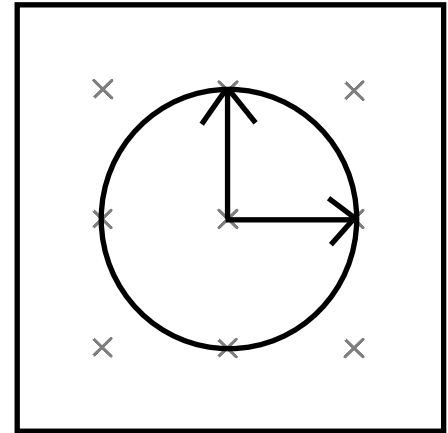
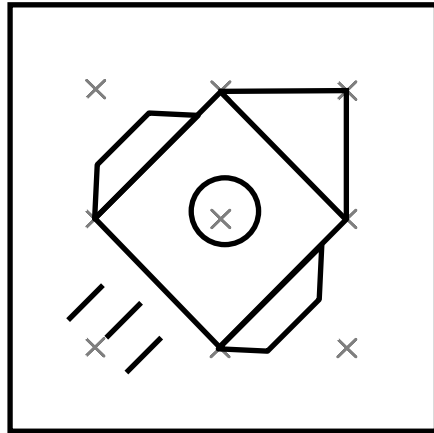
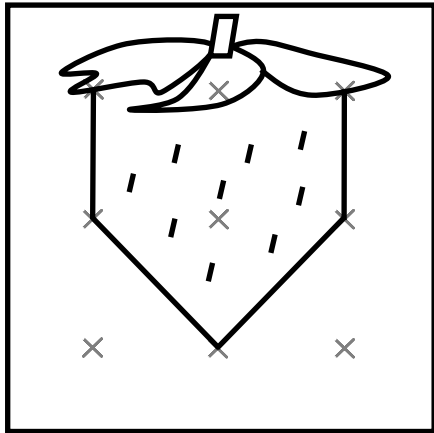



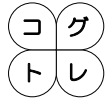

# てん 点つなぎ ① - 9

ねん 年      がつ 月      にち 日      なまえ 名前 ( )

うえ 上      え 絵      おな おな      した 下      うつ 写  
上の絵と同じように × をつないで下に写しましょう。

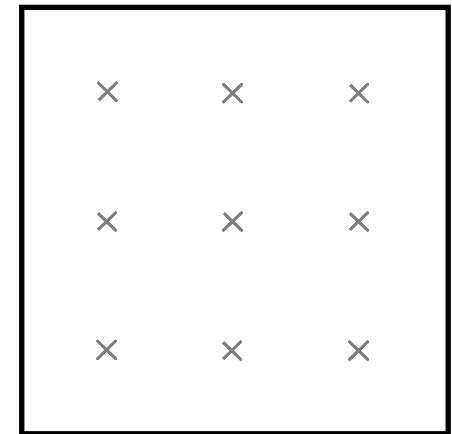
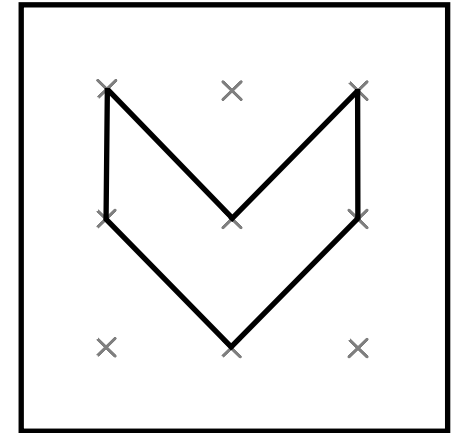
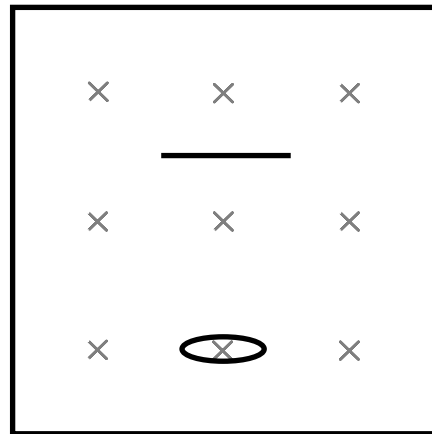
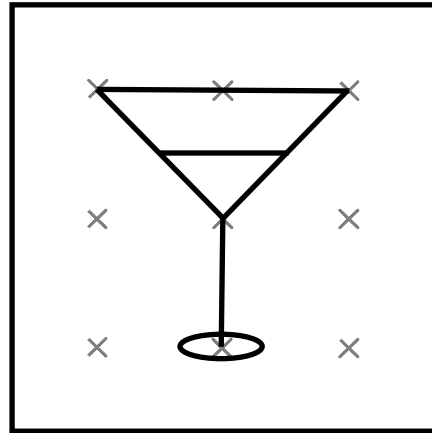
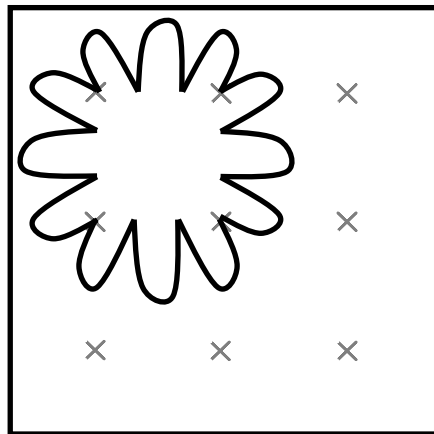
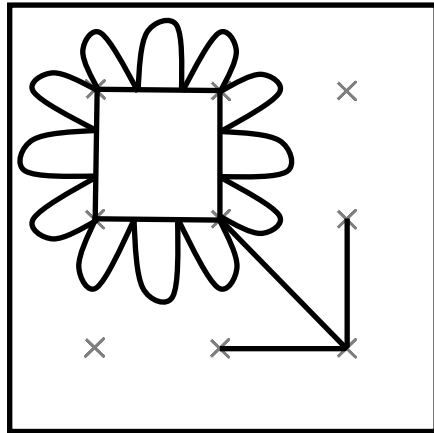

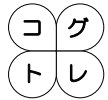

# てん 点つなぎ ① - 10

ねん がつ にち なまえ ( )  
年 月 日 名前

うえ え おな  
上の絵と同じように × をつないで下に写しましょう。  
した うつ

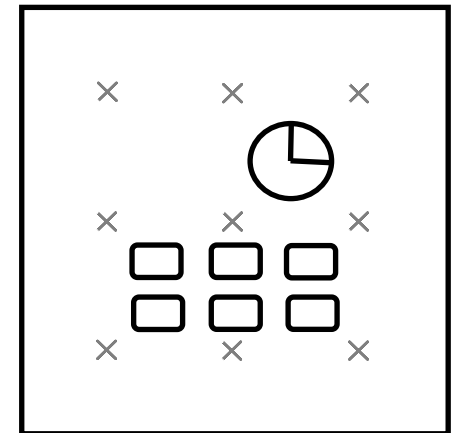
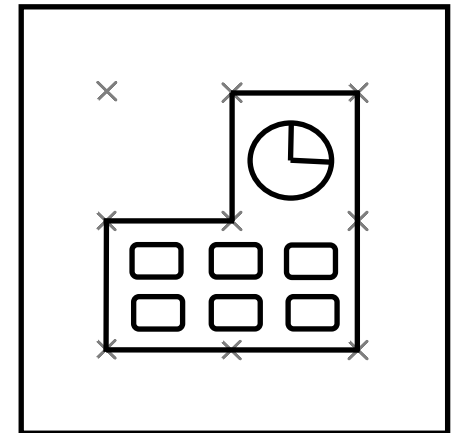
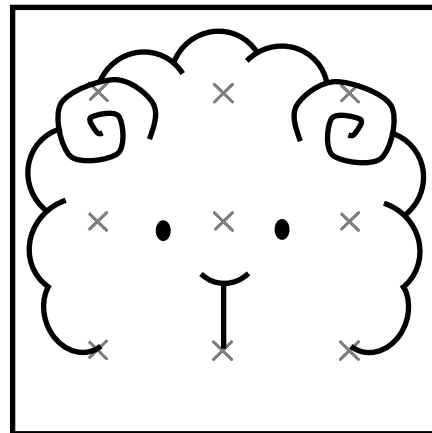
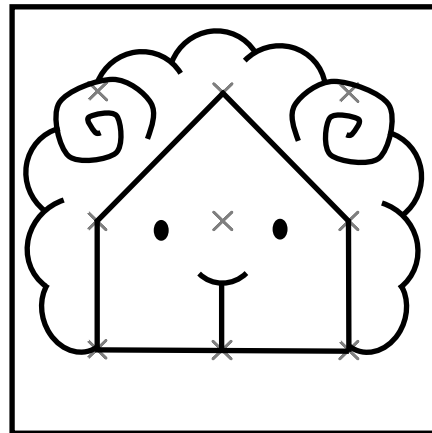
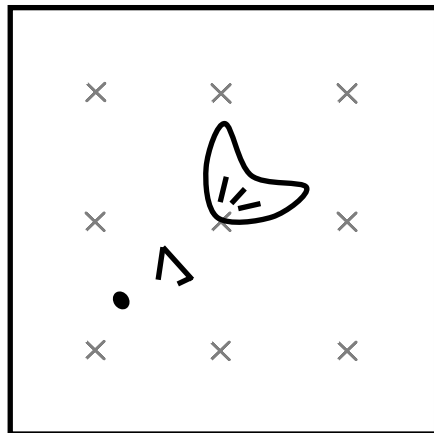
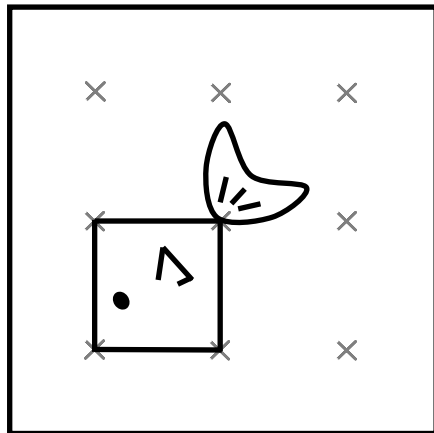

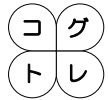

# てん 点つなぎ ① - 11

ねん 年    がつ 月    にち 日    なまえ 名前 (    )

うえ 上    え 絵    おな おな    した 下    うつ 写  
上の絵と同じように × をつないで下に写しましょう。

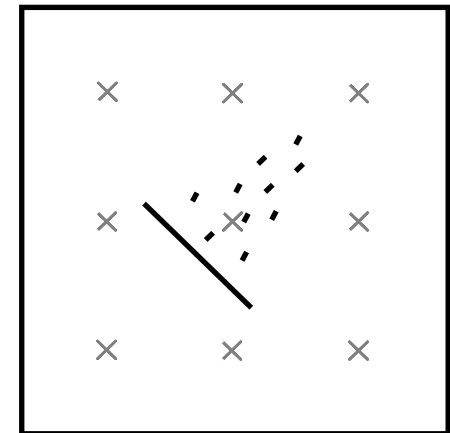
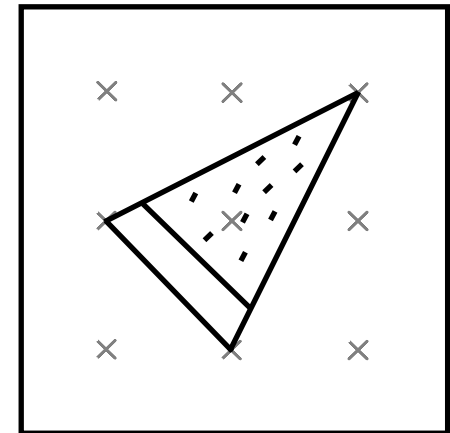
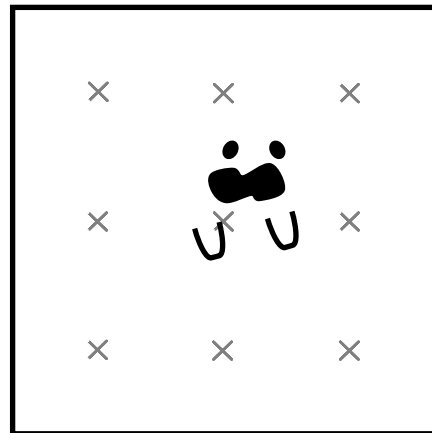
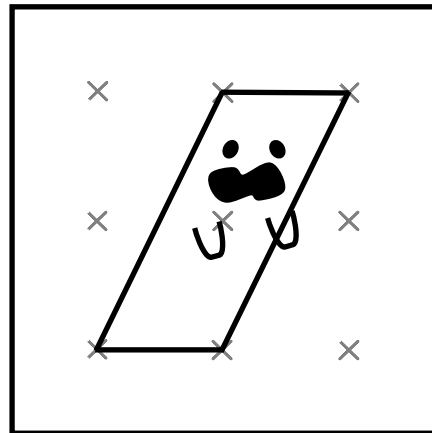
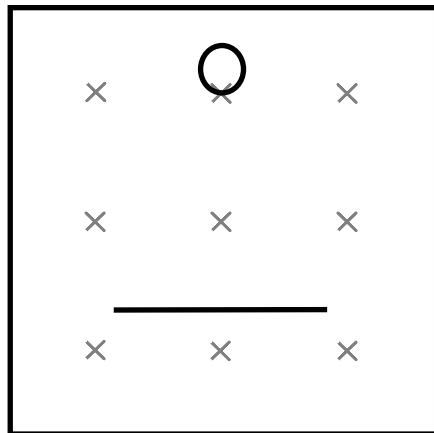
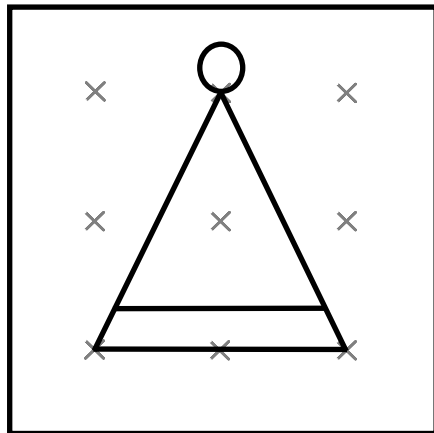

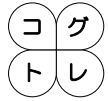

# てん 点つなぎ ① - 12

ねん 年    がつ 月    にち 日    なまえ 名前 (    )

うえ え おな    した うつ  
上の絵と同じように × をつないで下に写しましょう。

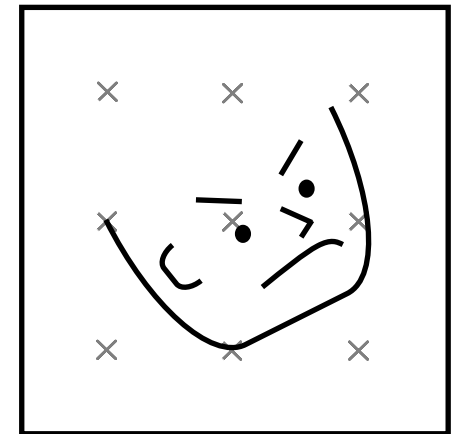
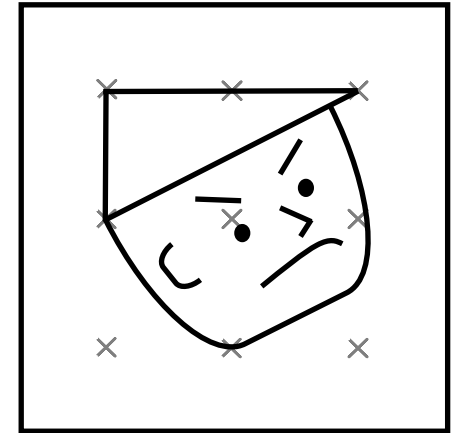
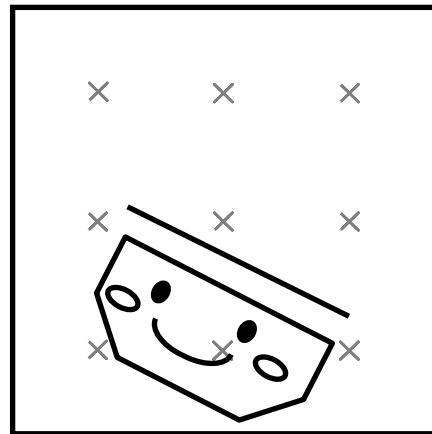
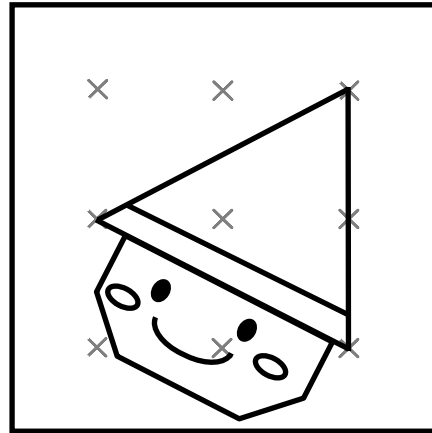
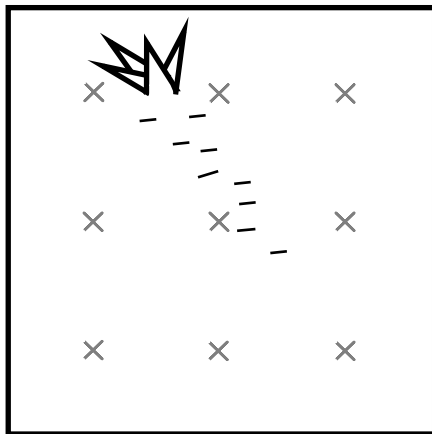
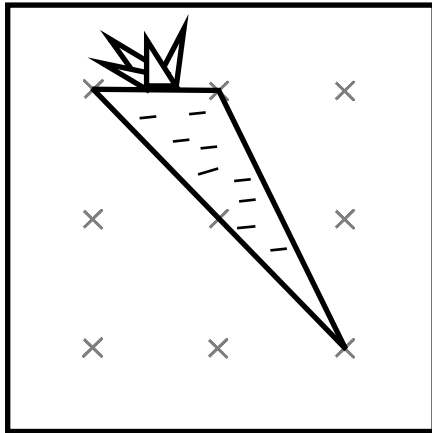

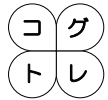

てん  
点つなぎ ① - 13

ねん がつ にち なまえ ( )  
年 月 日 名前

うえ え おな  
上の絵と同じように × をつないで下に写しましょう。

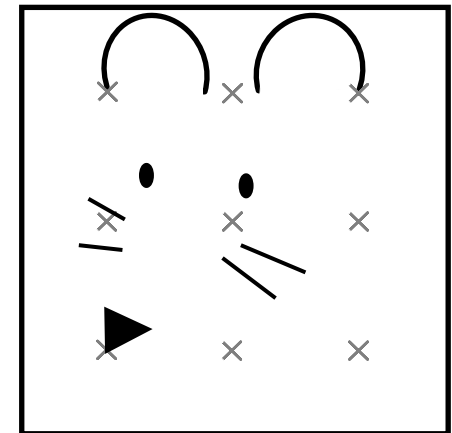
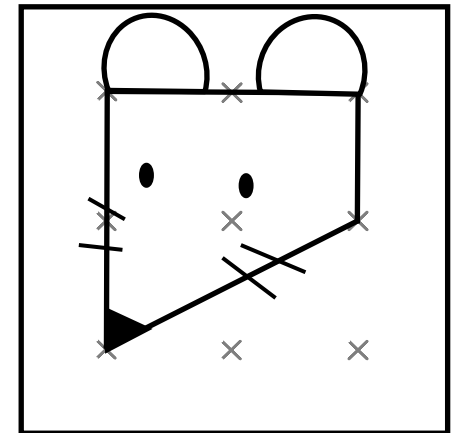
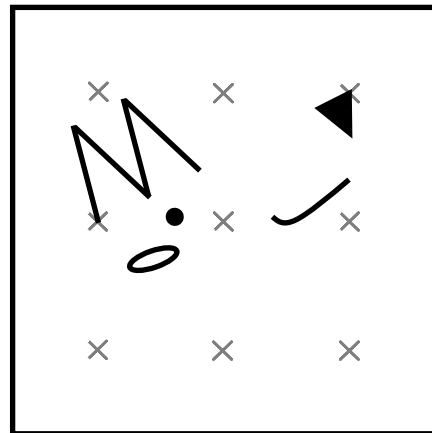
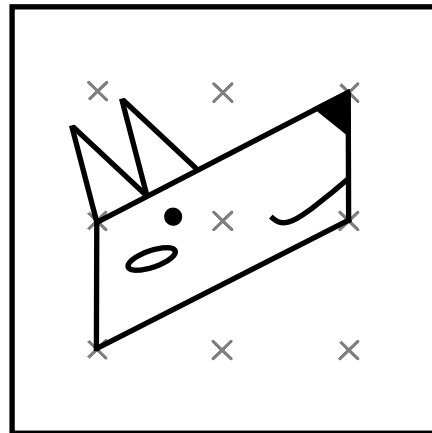
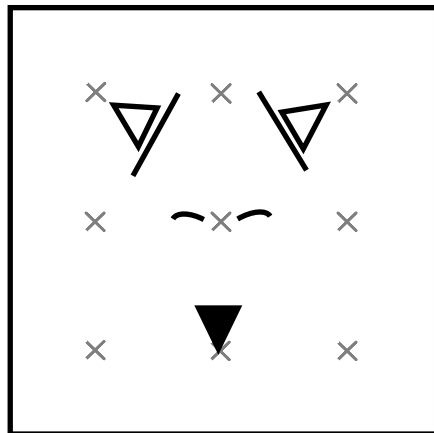
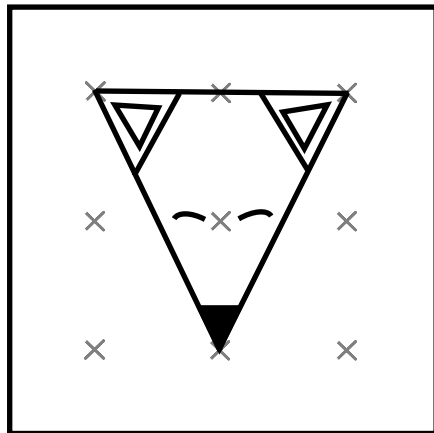

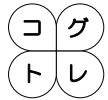

てん  
点つなぎ ① - 14

ねん がつ なまえ ( )  
年 月 日 名前

うえ え おな  
上の絵と同じように × をつないで下に写しましょう。  
した うつ

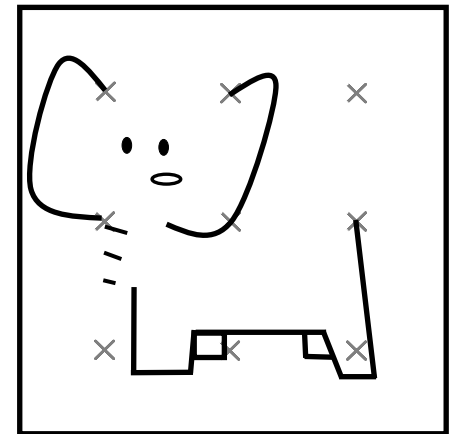
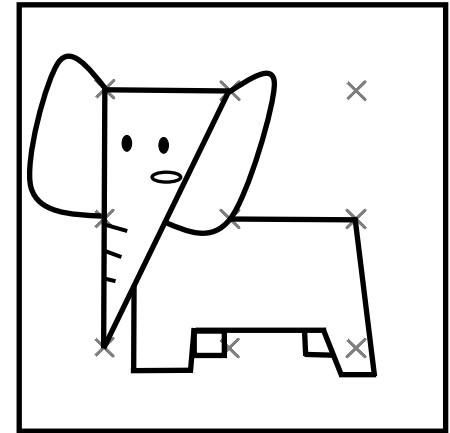
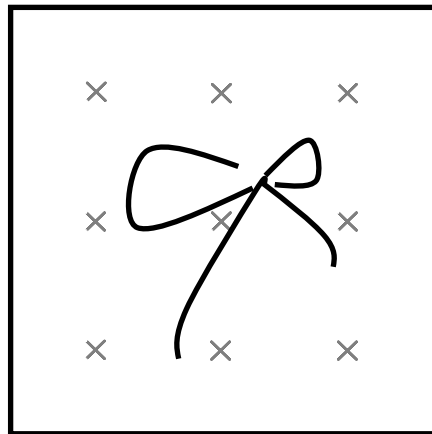
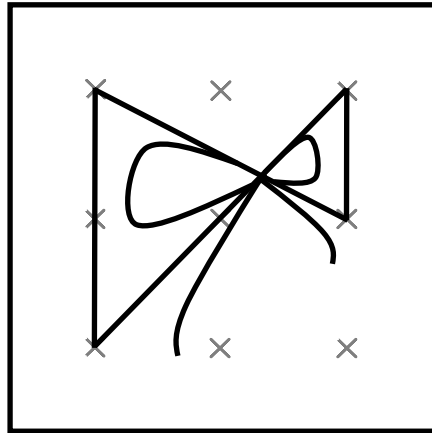
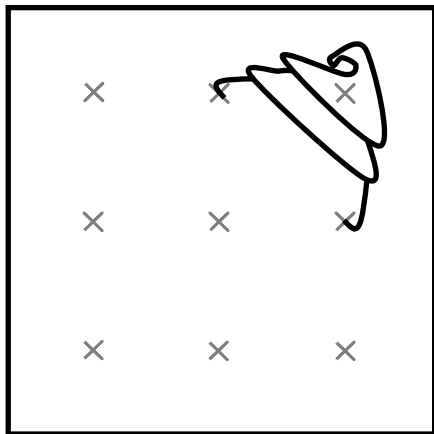
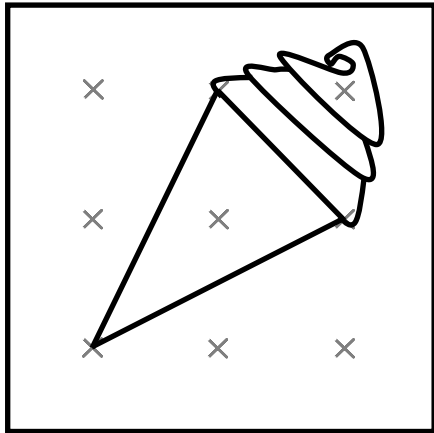

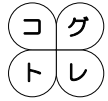

てん  
点つなぎ ① - 15

ねん 年      がつ 月      にち 日      なまえ 名前 ( )

うえ え おな      した うつ  
上の絵と同じように × をつないで下に写しましょう。

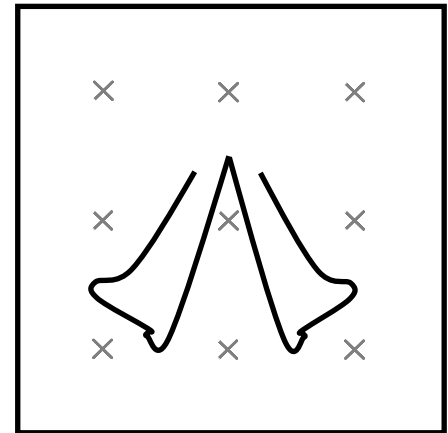
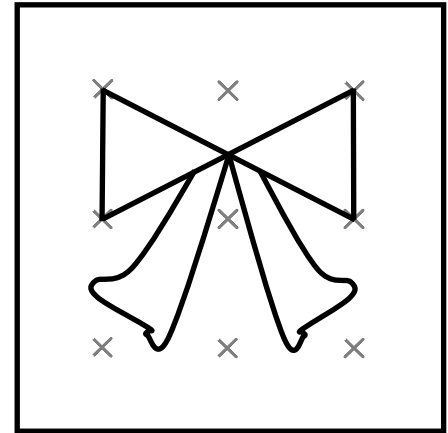
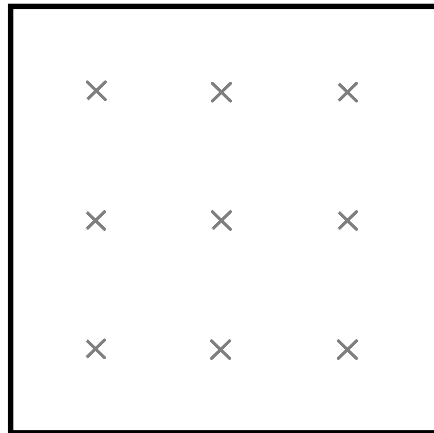
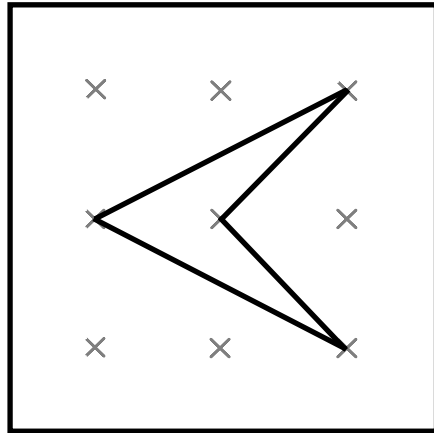
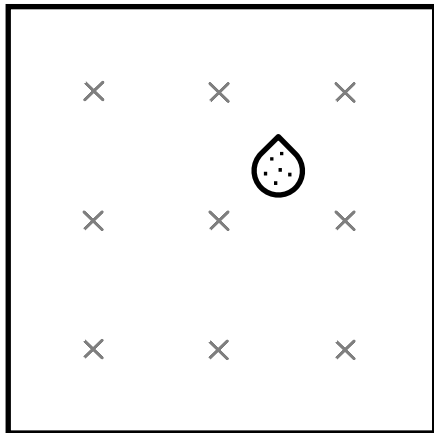
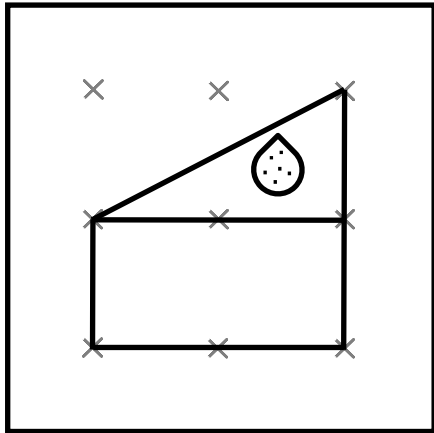

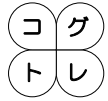

# てん 点つなぎ ① - 16

ねん 年    がつ 月    にち 日    なまえ 名前 (    )

うえ え おな    した うつ  
上の絵と同じように × をつないで下に写しましょう。

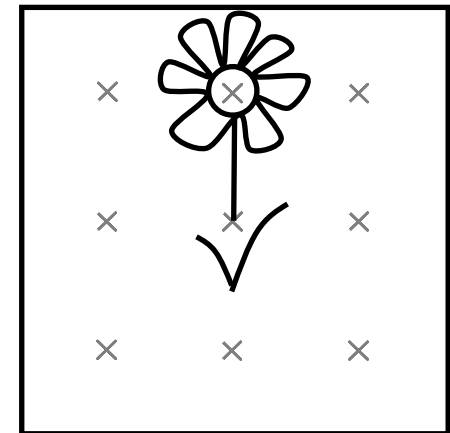
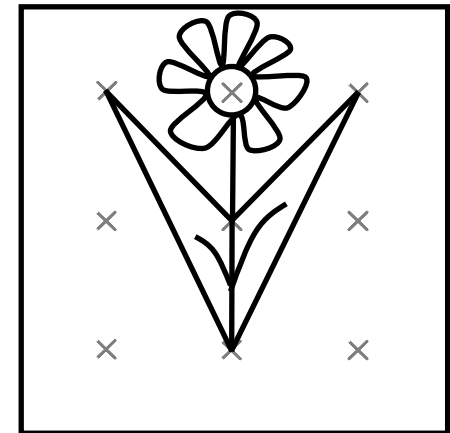
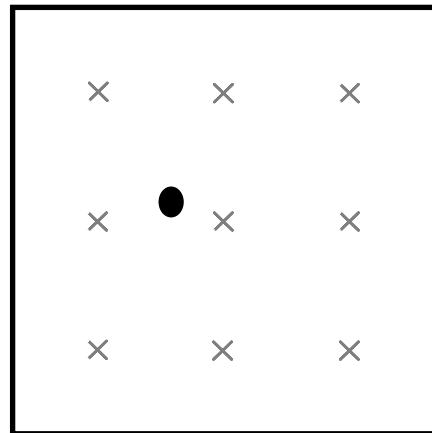
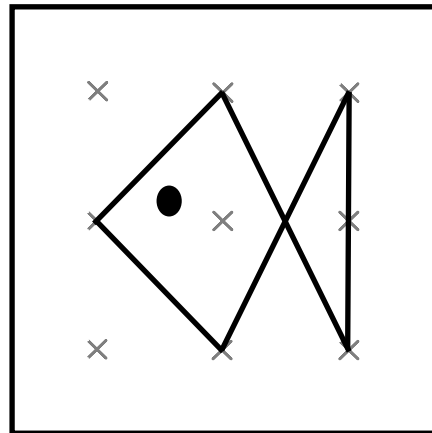
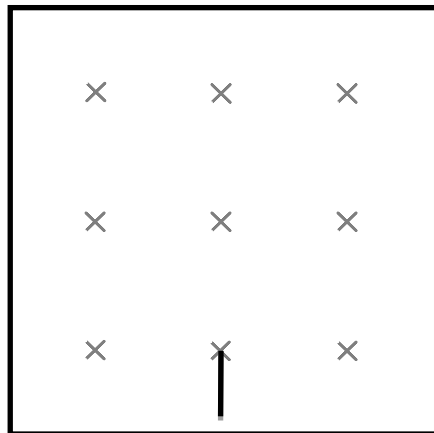
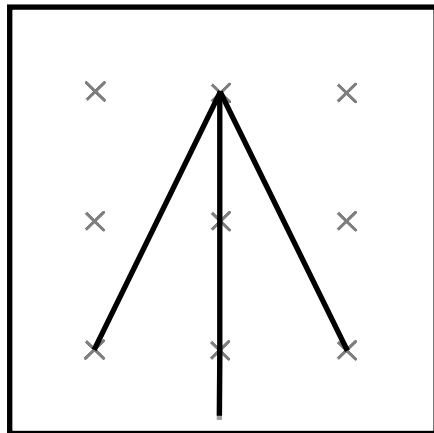





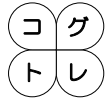

# てん 点つなぎ ① - 18

ねん がつ にち なまえ ( )  
年 月 日 名前

うえ え おな  
上の絵と同じように × をつないで下に写しましょう。

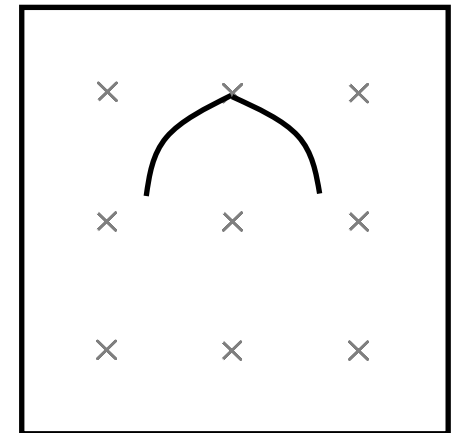
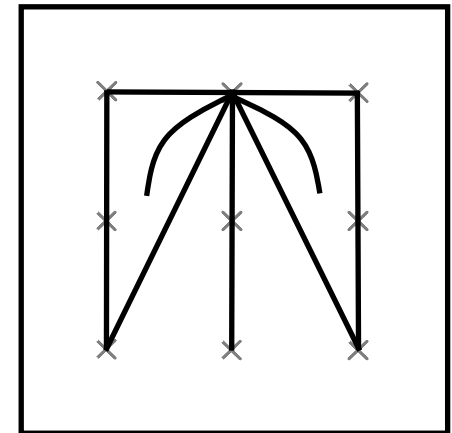
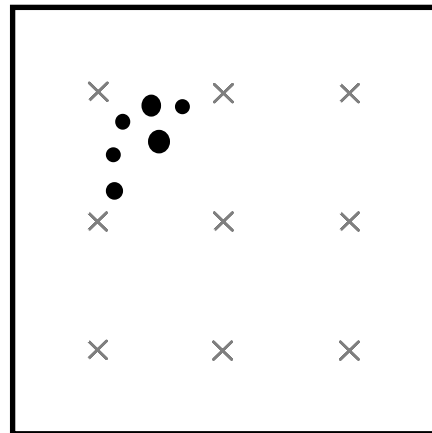
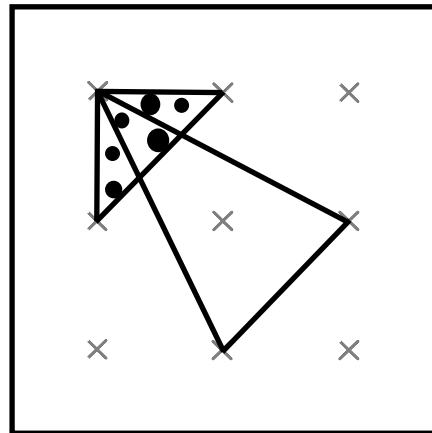
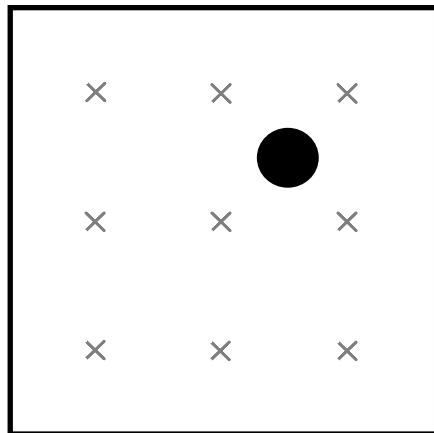
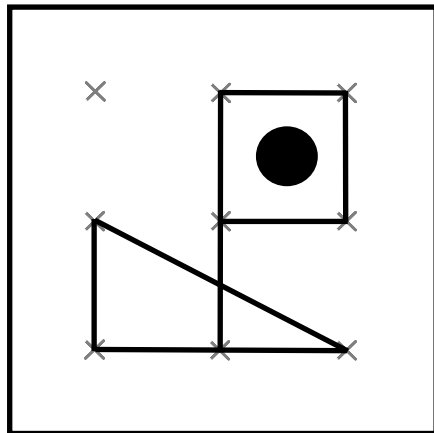

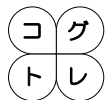

# てん 点つなぎ ① - 19

ねん 年    がつ 月    にち 日    なまえ 名前 (    )

うえ え おな    した うつ  
上の絵と同じように × をつないで下に写しましょう。

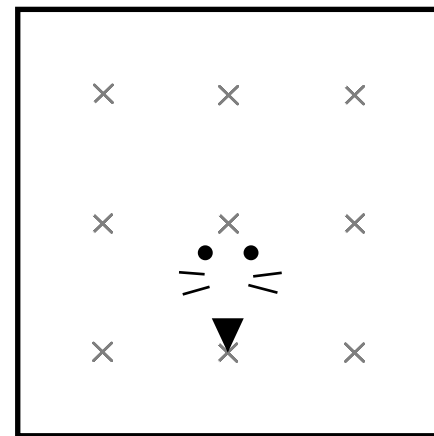
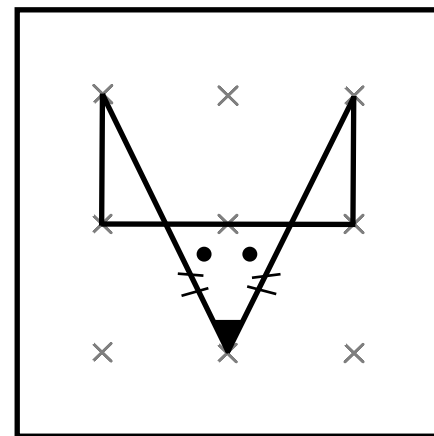
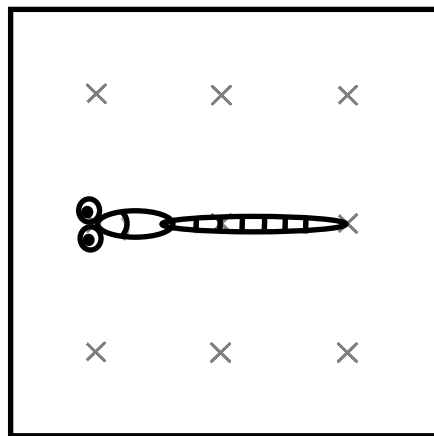
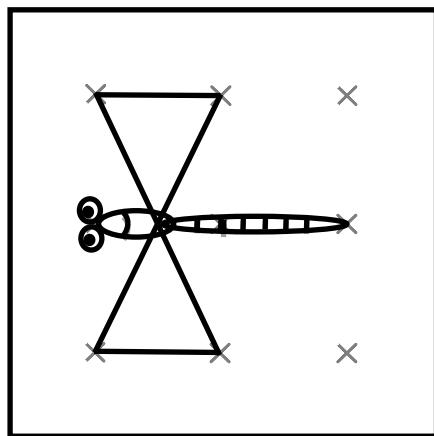
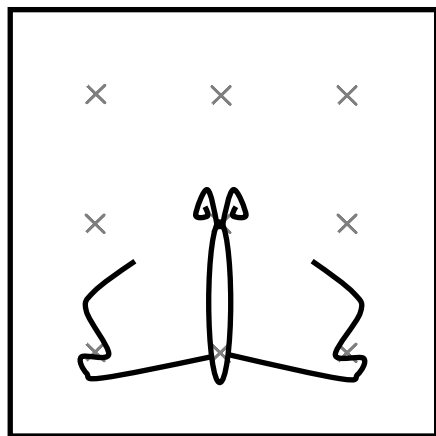
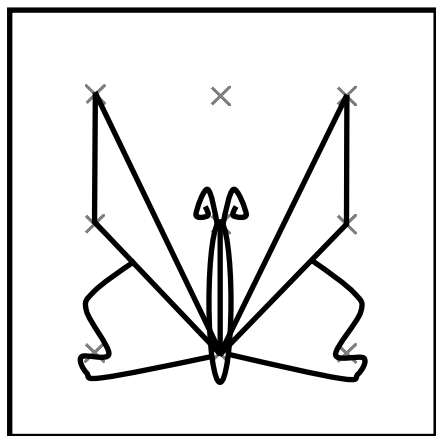



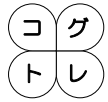

# てん 点つなぎ ① - 21

ねん 年    がつ 月    にち 日    なまえ 名前 (    )

うえ え おな    した うつ  
上の絵と同じように × をつないで下に写しましょう。

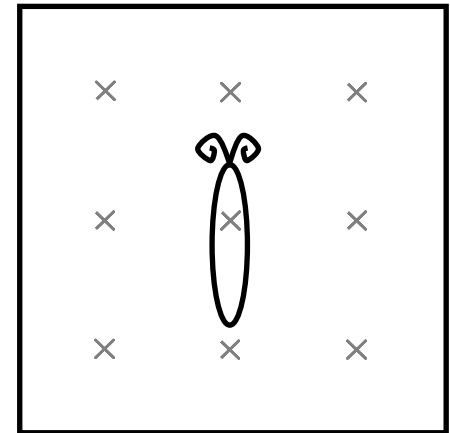
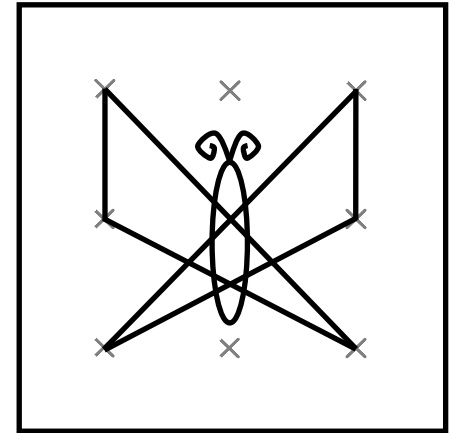
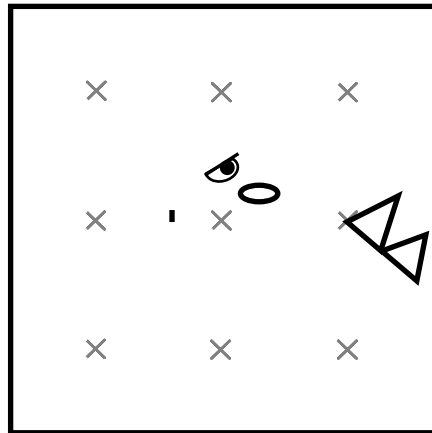
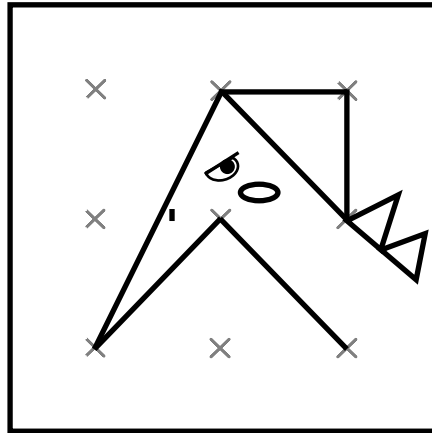
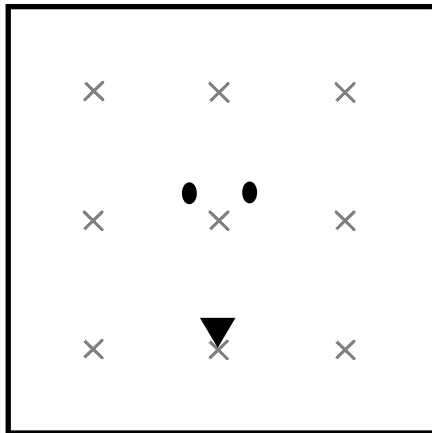
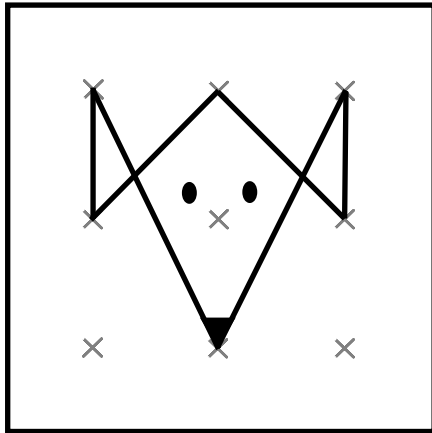

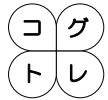

# てん 点つなぎ ① - 22

ねん 年    がつ 月    にち 日    なまえ 名前 (    )

うえ え おな    した うつ  
上の絵と同じように × をつないで下に写しましょう。

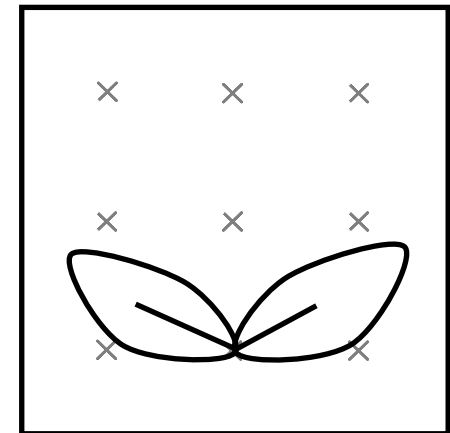
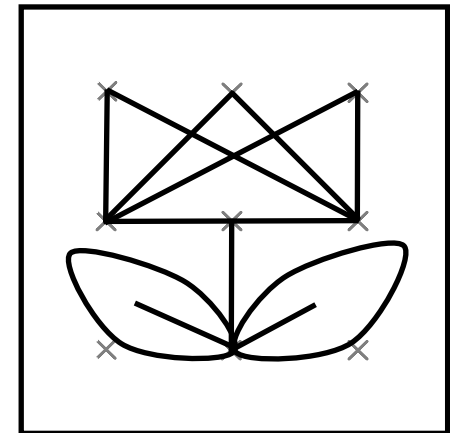
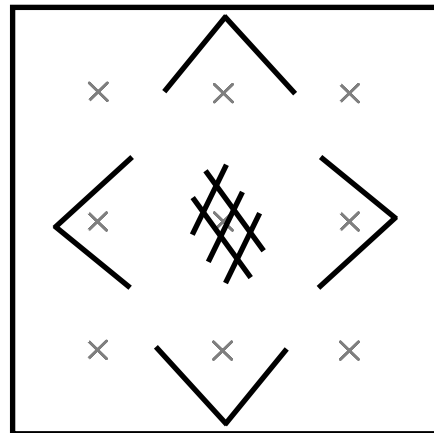
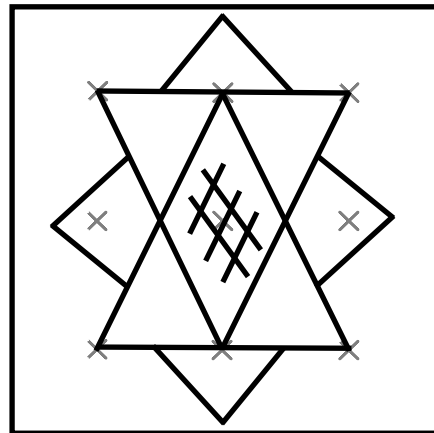
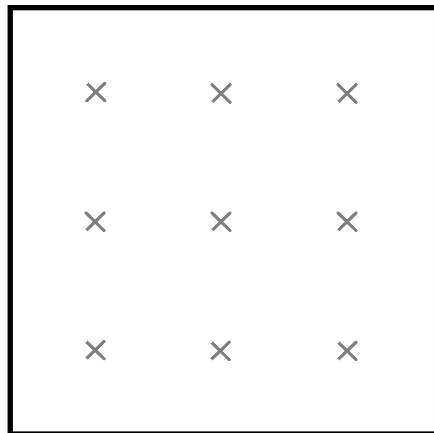
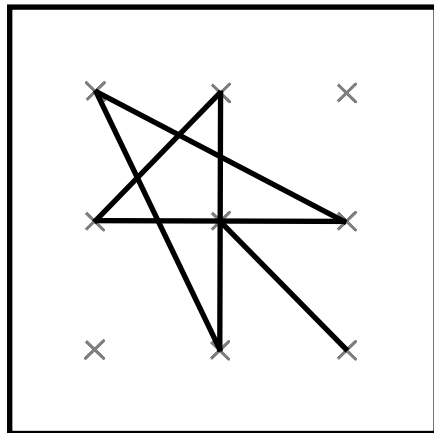

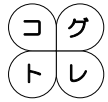

# てん 点つなぎ ① - 23

ねん 年    がつ 月    にち 日    なまえ 名前 (    )

うえ え おな    した うつ  
上の絵と同じように × をつないで下に写しましょう。

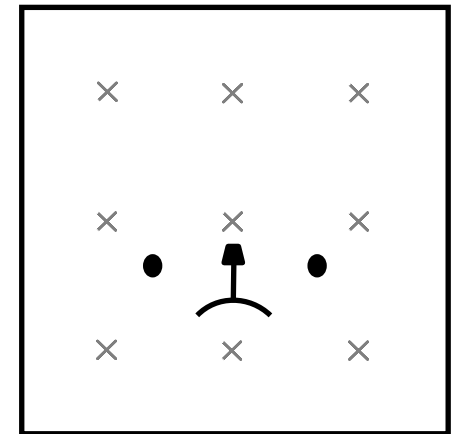
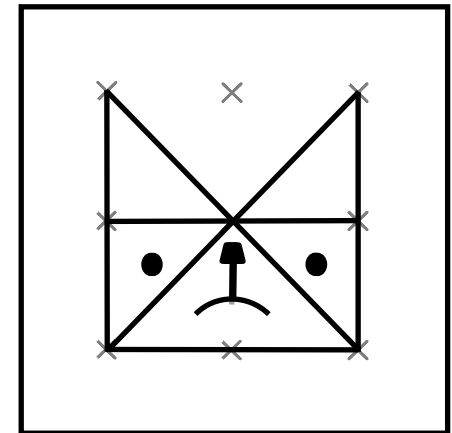
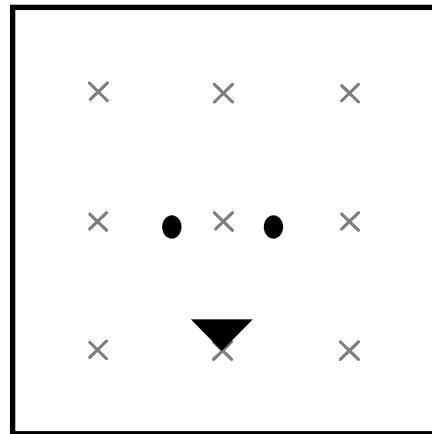
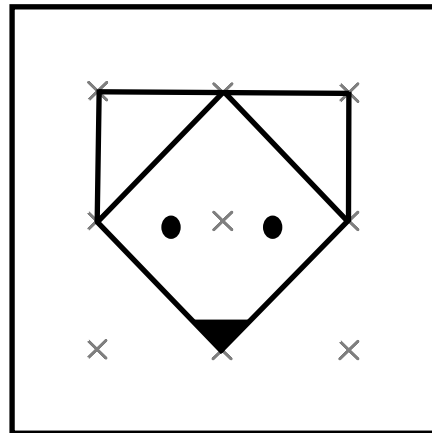
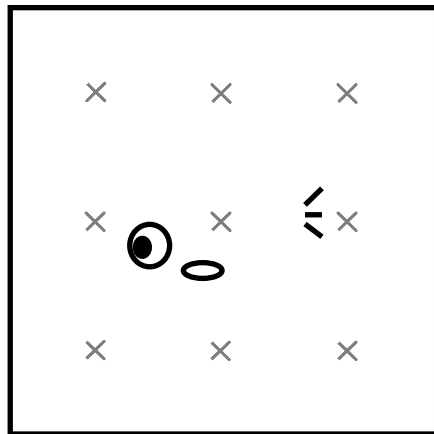
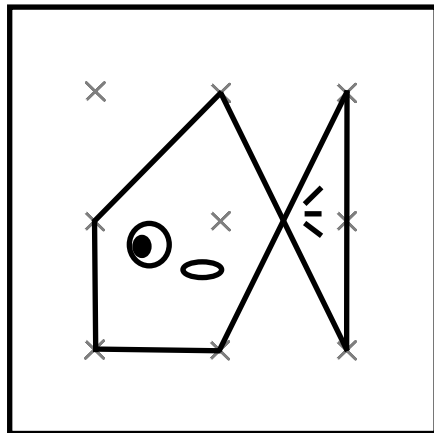

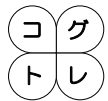

# てん 点つなぎ ① - 24

ねん 年    がつ 月    にち 日    なまえ 名前 (    )

うえ 上    え 絵    おな おな    した 下    うつ 写  
上の絵と同じように × をつないで下に写しましょう。

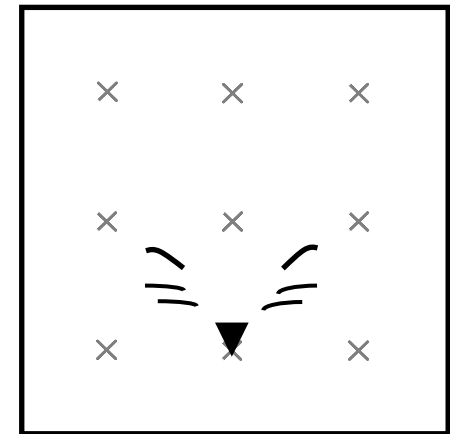
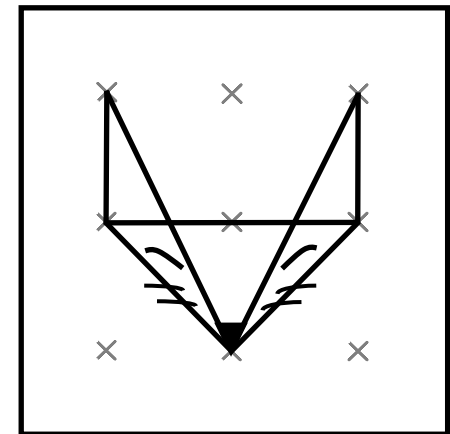
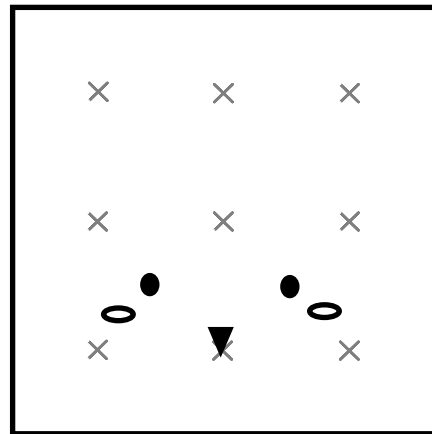
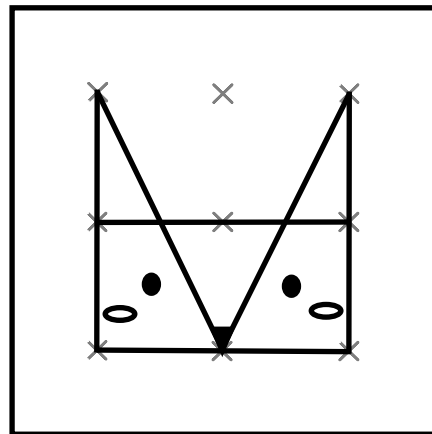
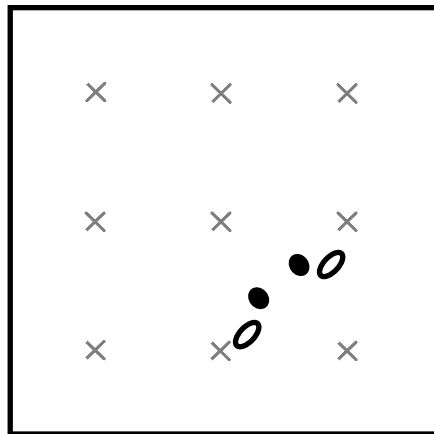
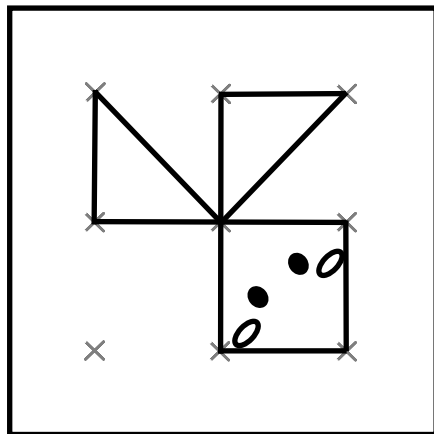



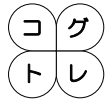

# てん 点つなぎ ① - 25

ねん 年    がつ 月    にち 日    なまえ 名前 (    )

うえ え おな    した うつ  
上の絵と同じように × をつないで下に写しましょう。

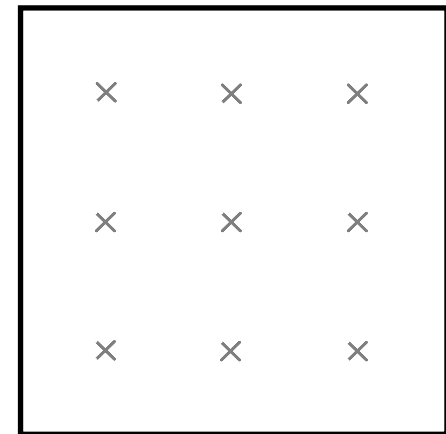
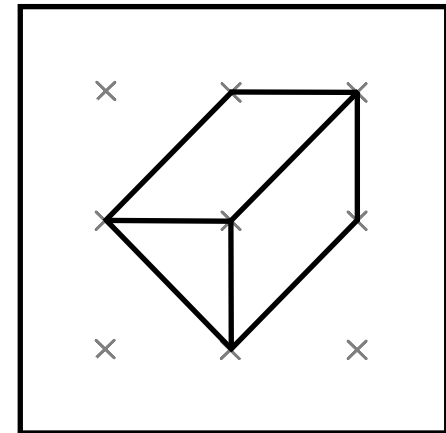
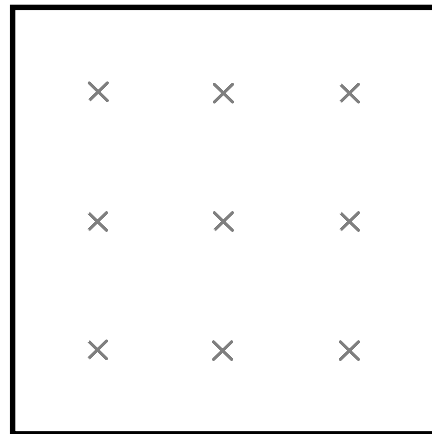
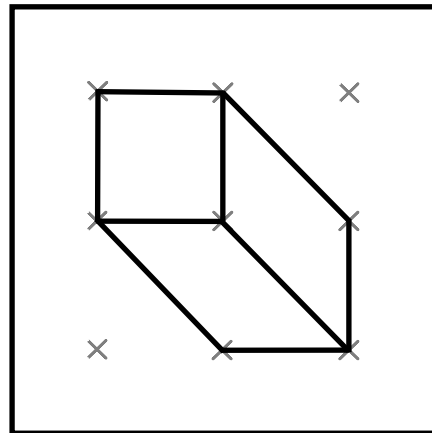
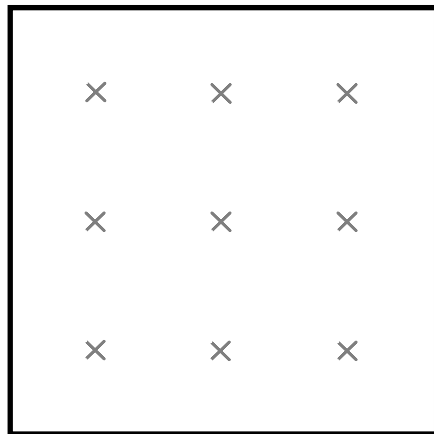
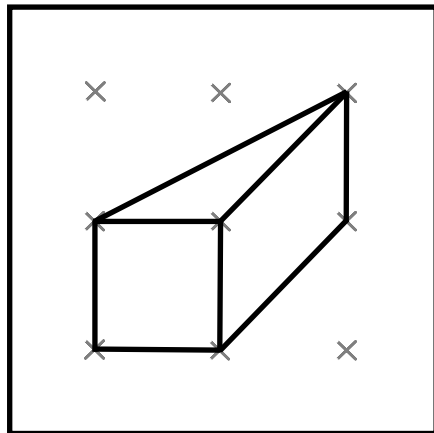



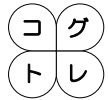

# てん 点つなぎ ① - 27

ねん がつ にち なまえ ( )  
年 月 日 名前

うえ え おな  
上の絵と同じように × をつないで下に写しましょう。

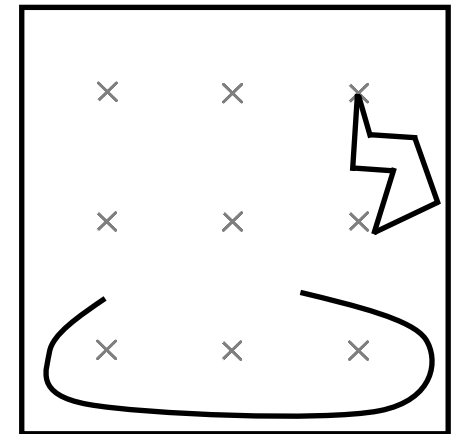
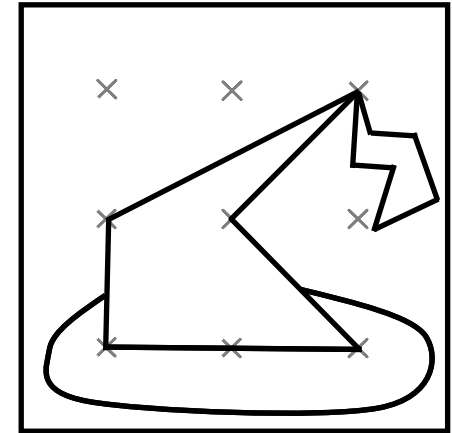
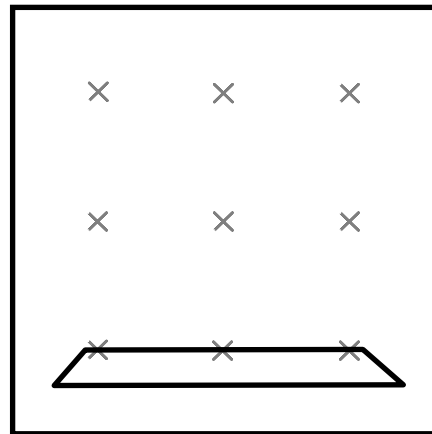
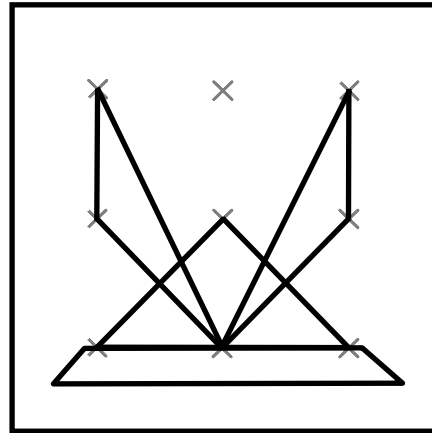
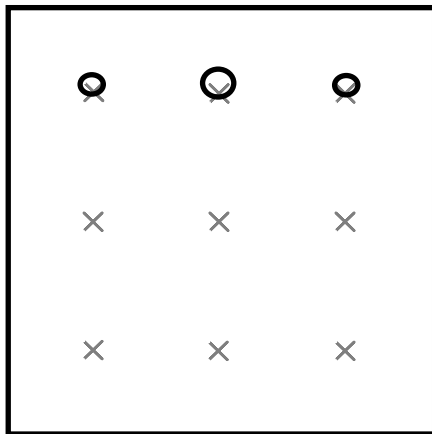
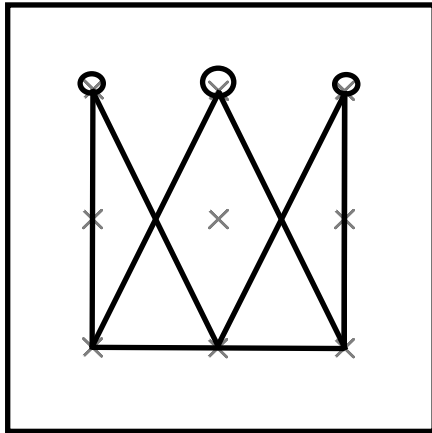

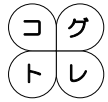

# てん 点つなぎ ① - 28

ねん 年    がつ 月    にち 日    なまえ 名前 ( )

うえ 上    え 絵    おな おな    した 下    うつ 写  
上の絵と同じように × をつないで下に写しましょう。

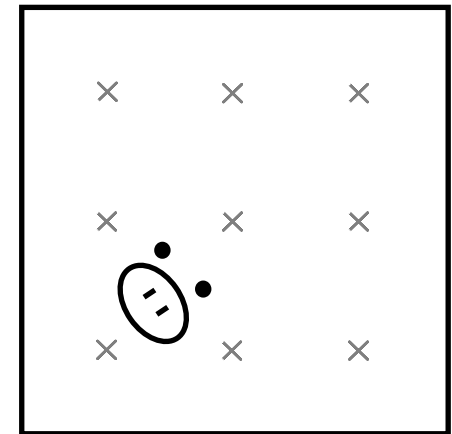
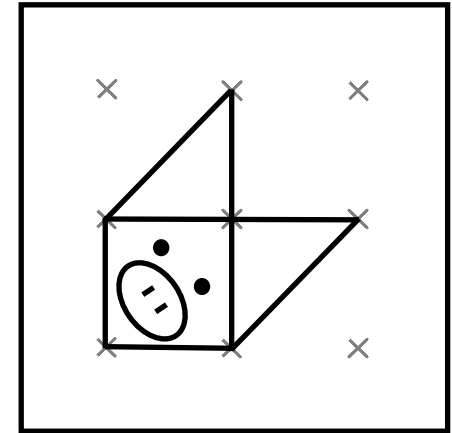
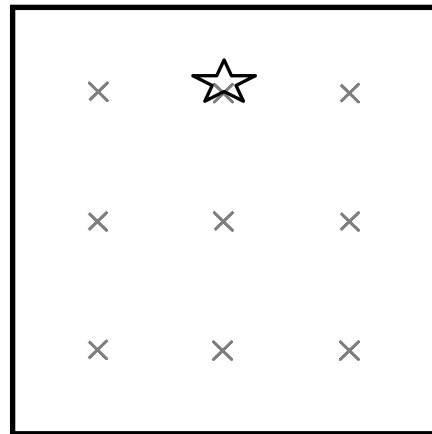
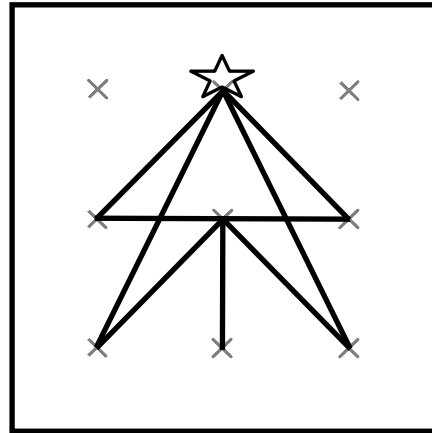
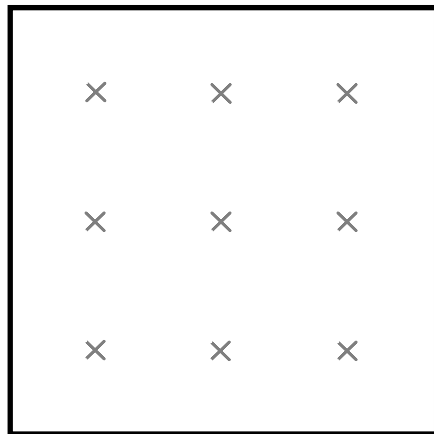
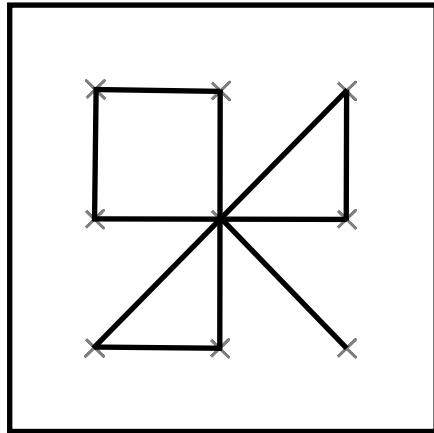

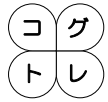

# てん 点つなぎ ① - 29

ねん 年    がつ 月    にち 日    なまえ 名前 ( )

うえ え おな    した うつ  
上の絵と同じように × をつないで下に写しましょう。

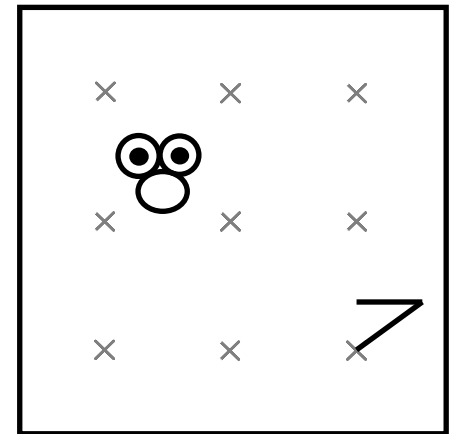
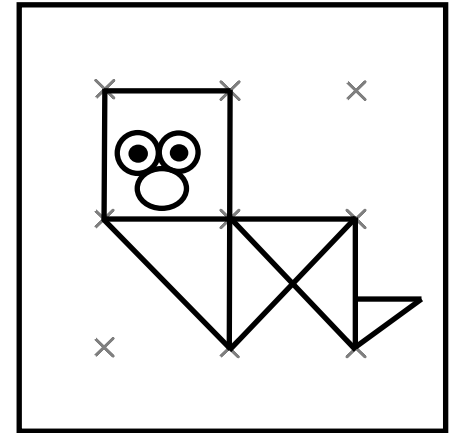
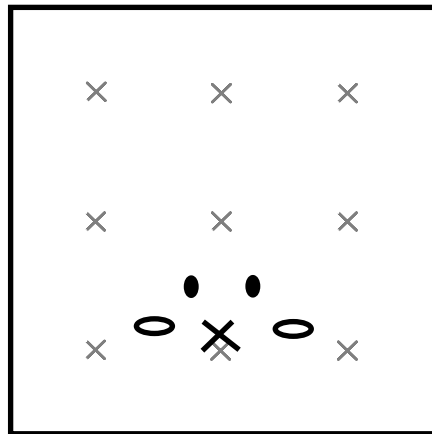
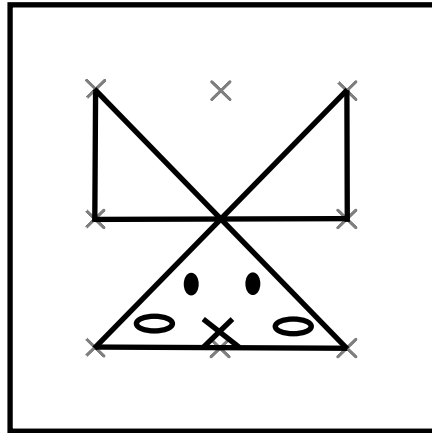
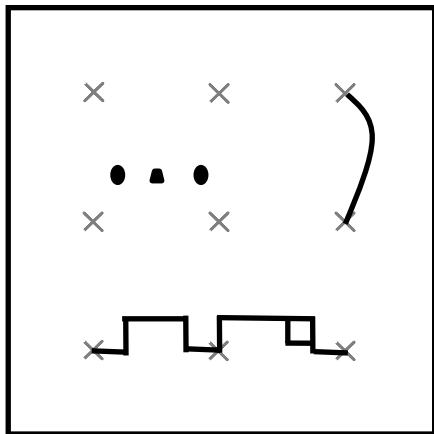
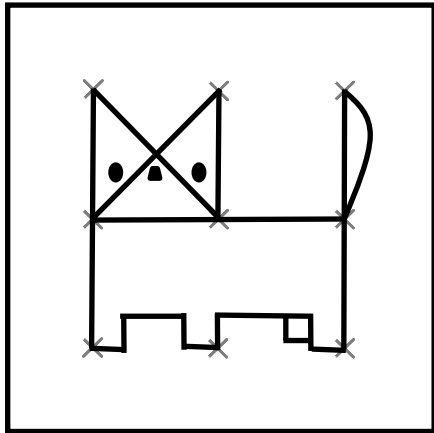

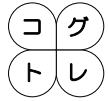

てん  
点つなぎ ① - 30

ねん がつ にち なまえ ( )  
年 月 日 名前

うえ え おな  
上の絵と同じように × をつないで した うつ  
下に写しましょう。

